

MARITIME APPLICATIONS OF AN ADVANCED GAS-COOLED
REACTOR PROPULSION SYSTEM

Capt. Richards T. Miller, USN (Retired)
R. E. Thompson

The Society of Naval Architects and Marine Engineers
1977 Spring Meeting and STAR Symposium
San Francisco, California
May 25-27, 1977

WESTINGHOUSE ELECTRIC CORPORATION

Abstract

The paper describes the results of studies to determine the feasibility of a light weight nuclear propulsion system (LWNP) conceptual design for marine applications. The powerplant design concept is based upon nuclear rocket reactor and other existing technologies. It consists of a gas-cooled nuclear reactor and integrally packaged gas turbine propulsion system. The selected power cycle, which uses helium at 1700^oF and 1500 psia in a closed Brayton cycle, is diagrammed and described. The nuclear reactor uses technologies developed and demonstrated in both the nuclear rocket and the land-based gas cooled commercial reactor programs. Conceptual designs are presented to demonstrate the feasibility of, and the advantages to be gained by substituting the LWNP for aircraft derivative marine gas turbines in a high performance displacement ship and cargo liner.

Introduction

Studies of the application of nuclear power for propulsion of vehicles which are highly weight sensitive and/or highly volume sensitive have been performed by Westinghouse engineers and scientists since 1972. The studies have been directed toward definition of practical powerplants for which the basic technology is already available or being developed in separate, independent programs. The nuclear rocket technologies have been one of the important bases for these studies.

The purpose of these studies has been to evaluate feasibility and practicality by preparing a powerplant design for a representative application in sufficient detail for such evaluation. An additional purpose has been to provide characteristic data for scaling and adapting to other applications. A single, demanding application and one plant rating were chosen for examination in depth, limited of course by the effort which could be applied. The major objectives of the study can be summarized in three questions:

- Is a light weight nuclear powerplant feasible for such an application?
- Does the basic technology exist to initiate

a development and demonstration program for a light weight nuclear powerplant?

- Where problems are identified, can at least one engineering solution be identified?

The feasibility studies were initially accomplished using a Surface Effects Ship (SES) as the representative application. The SES places stringent requirements on the powerplant because of weight and volume limitations. Some results have been summarized in References 1, 2, and 3. Numerous engineering variations of the representative design have been studied.

As a result of the studies, it has been concluded by Westinghouse that the LWNP is both feasible and practical. It is also believed that sufficient conservatism has been included to insure that the projected characteristics are realistic estimates of the characteristics which would be exhibited by such a powerplant after its development has been accomplished. It should be recognized that even though the technology already exists, a major development program is required for the LWNP. However, it should also be recognized that a separate development program is not required for each application of the LWNP. The concept is such that, if developed, it could be applied with a very high degree of commonality to a wide range of applications. This paper addresses one of the potential applications, that of a propulsion system for displacement ships.

As a basis for evaluation of the suitability of the Light Weight Nuclear Powerplant (LWNP) for maritime displacement ship propulsion, it was desired to determine if a LWNP could provide the same, or higher, power output as an existing aircraft derivative marine gas turbine, fit within the engine room space occupied by a comparable open cycle gas turbine and provide operational or economic incentives for the change. This purpose resulted in the assumed top level requirements summarized in Table I. Fulfillment of these requirements would indicate that use of LWNP's would be possible from the powerplant standpoint. The powerplant weight limitation listed in Table I was taken to be the total of the weights of the components which would be eliminated in such a change and of the fossil fuel which would no longer be needed. The nuclear

TABLE I

ASSUMED REQUIREMENTS

GENERAL

- The powerplant must fit within space normally allotted to the replaced engine, fuel and ductwork.
- The powerplant must interface with previous installed reduction gears.
- No significant alteration of personnel spaces outside of the engine room should be required because of the nuclear powerplant.

SPECIFIC

Output Shaft Power	25,000 HP
Full Power Lifetime	10,000 Hrs
Maximum Dimensions (Replaceable Module)	8'-9" W x 14' H x 26'-6" L
Approximate Maximum Specific Weight	25 Lb/HP
Shielding	1 Millirem/Hr at the Surface of the Shield in the Direction of Occupied Areas at Full Power

powerplant weights discussed in this paper therefore include only the weights of those items which are peculiar to the nuclear powerplant. Such a definition of powerplant scope therefore allows a direct comparison and consideration of any weight changes due to use of LWNPs.

The Light Weight Nuclear Powerplant

The study requirements assumed a desirability to interface with bed plates and reduction gears designed for the LM-2500 gas turbine. They also assumed the suitability of the very restrictive dose rate limitations which have been used in recent safety studies of nuclear powerplants for merchant ships. The assumption was made that the shielding must be sufficient to permit unlimited occupancy outside of the engine room.

Trade-off studies indicated the desirability of a compact closed Brayton power conversion system with recuperation and one stage of intercooling using helium as the working fluid. A schematic diagram of the closed cycle flow path is shown in Figure 1. Overall cycle pressure ratio is weight optimized at approximately 3.7. Heat rejection from the precoolers and intercoolers is to an intermediate heat transfer system which in turn rejects heat to seawater through a seawater heat exchanger as shown in Figure 2. Typical temperature/entropy conditions are shown in Figure 3. Reactor outlet conditions of 1700°F and 1500 psia were

selected after consideration of cycle and materials requirements and technology and were primarily determined by considerations associated with the gas turbines. These conditions provide an attractive overall cycle efficiency and a compact powerplant which can be achieved within the expected capability of superalloy materials without requiring cooling of the turbine blades.

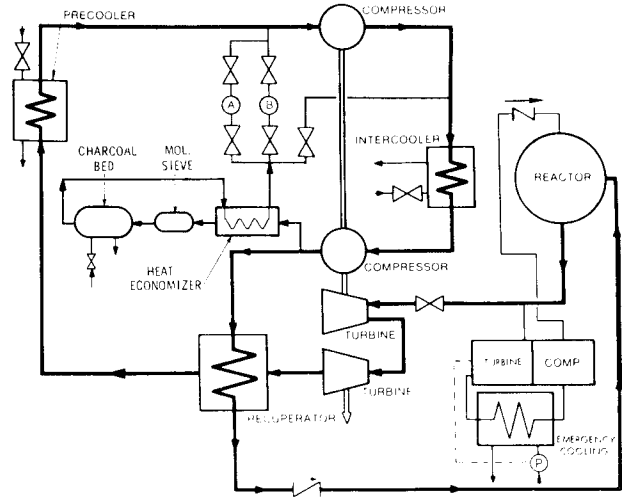

Figure 1. Powerplant Schematic

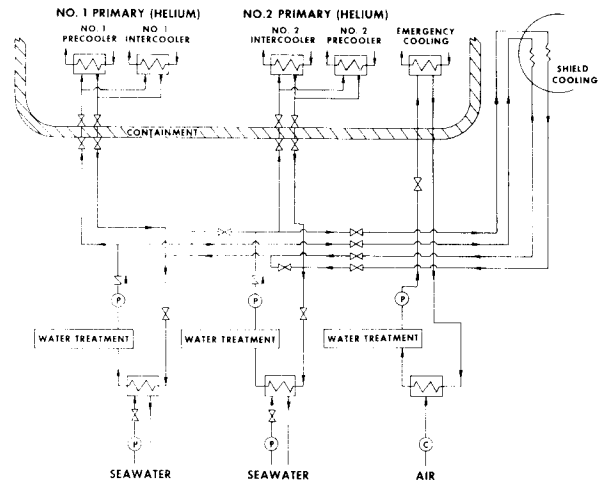

Figure 2. Intermediate Heat Rejection Systems

The molecular sieve and cooled charcoal bed shown in Figure 1 reduce the small amount of activity which could be present in the primary system due to fission products. The essentially clean helium from the charcoal bed is returned to the cycle during steady-state operations. Alternatively, the clean helium can be directed to storage volumes A or B. These storage volumes are part of the powerplant control system in the version of the LWNP under discussion. When used in conjunction with automatic reactor exit temperature control, valving of helium from the primary flow system

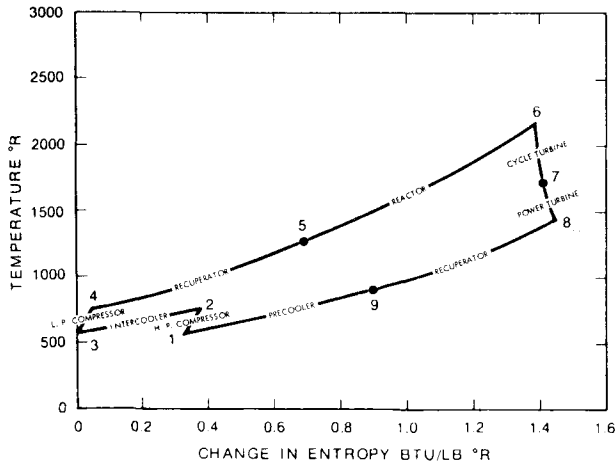

Figure 3. LWNP Cycle Diagram

into the storage volumes results in a decrease in output shaft power. Conversely, valving of helium from the storage volume into the primary flow path at the low pressure compressor inlet affects a power increase.

As with any nuclear plant, provision must be incorporated to insure removal of reactor decay heat. The emergency cooling system performs this function, without external power, and transfers the heat to its own intermediate heat transfer system and thence to ambient air through heat exchangers. The complete powerplant also includes the other usual powerplant auxiliary systems.

The powerplant module concept which resulted from the study is shown in Figure 4. The replaceable powerplant module is 8' - 9" wide, 11' - 9" high, and 24' - 3" long (overall powerplant width 9' - 6" and length 26' - 6"). The module contains the reactor, radiation shielding (including a "plug" shield which permits flow of helium while attenuating radiation), power conversion assemblies, control gas storage, fission product cleanup system, and emergency cooling system. All of the primary system components are contained within a thick-walled containment vessel for safety. Not shown on this view, for clarity, but included in the weight and total volume estimates are auxiliary system components outside of the main module such as the intermediate heat rejection system and seawater heat exchanger, lube system, control racks, etc.

Reference 2 describes the reactor in some detail. However, some discussion of the concept is warranted in this paper. The reactor assembly includes the fueled core, axial and radial reflectors, core support systems, radial tungsten shield and appropriate provisions for gas cooling of the high temperature structure. These components are contained within a pressure vessel. The reactor design draws heavily upon the demonstrated NERVA reactor design technology (References 4 and 5) and incorporates adaptations of those NERVA design features appropriate for this application

Like NERVA, the reactor is a gas-cooled graphite moderated, epithermal reactor with coated fuel beads dispersed in graphite elements, has a lateral sup-

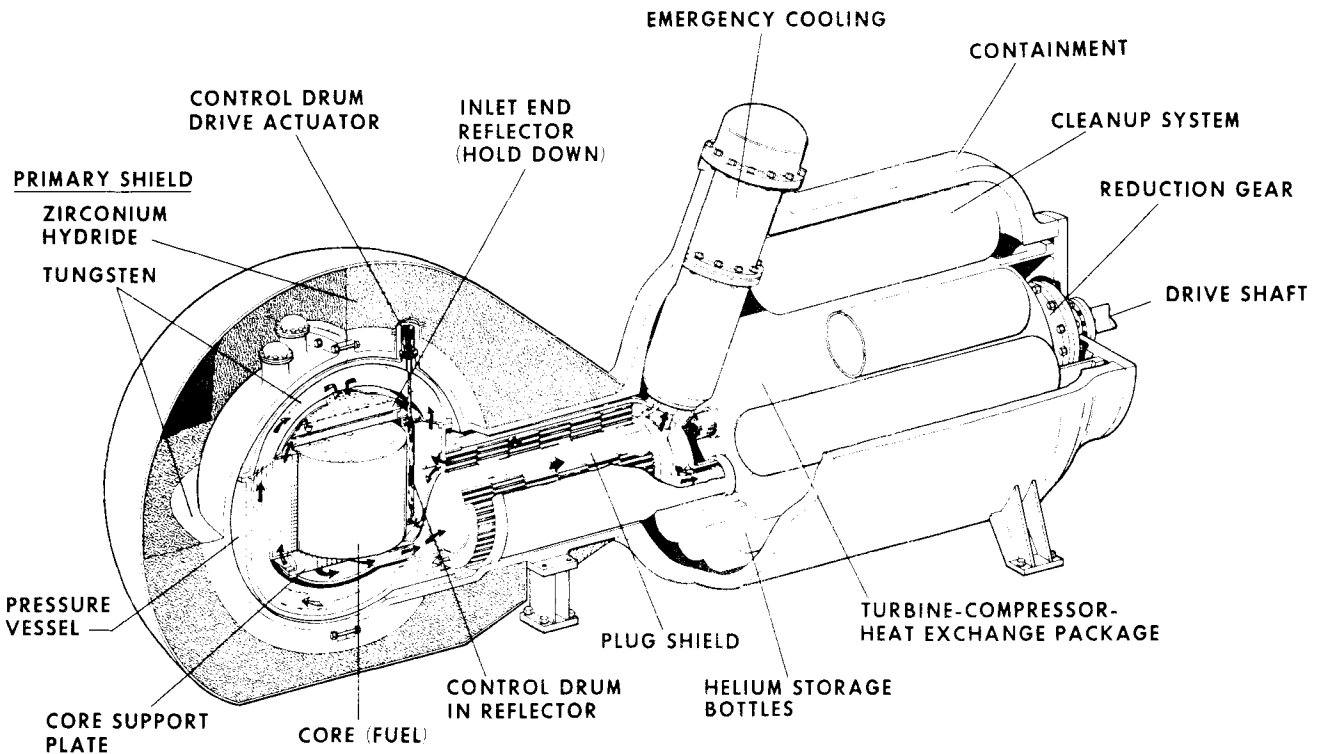

Figure 4. 25,000 SHP LWNP

port system to maintain core bundling and has a beryllium radial reflector with control drums. While fuel element fabrication is based on NERVA technology, the lower operating temperature permits the use of TRISO design fuel beads. The TRISO bead, developed and used in commercial gas-cooled reactors, provides high retention of fission products within the fuel bead itself as a barrier to fission product release. This is of great significance in enhancing the overall safety of the system. In view of the relatively low core exit temperature, the LWNP incorporates a hot end support plate, which was considered during the NERVA program as an alternate to in-core tie rods or tie-tubes, to minimize core size and reduce external shield and containment weight. A lateral support system adapted from the NERVA reactor provides radial bundling to position the core while still permitting the core dimensional changes which occur in operation. Based on the successful NERVA development and test program, there is a high degree of confidence that the LWNP reactor can be successful with a reasonable development program.

The reactor assembly, shown in Figure 5, consists of a fueled core surrounded by a reflector and internal shield, the whole assembly being contained in a pressure vessel. An external shield surrounds the assembly, except where the working fluid enters and leaves the reactor. At this location, the internal and external shields are replaced by a plug shield through which

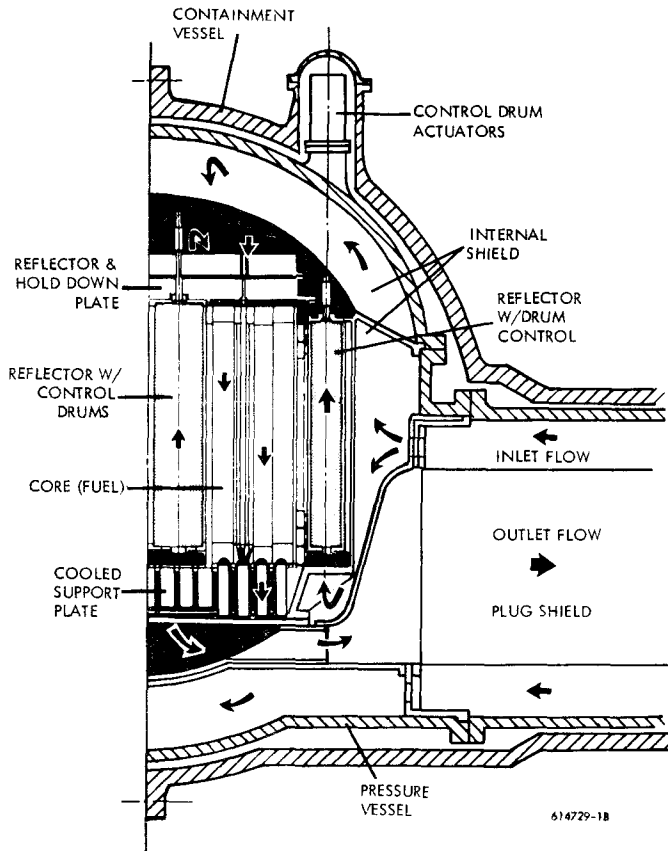

Figure 5. LWNP Reactor Configuration

the coolant enters and leaves in a coaxial arrangement. The tortuous flow passage geometry of the plug shield provides radiation shielding while permitting the flow of coolant.

The reactor core is constructed from fuel elements 30 inches in length and of hexagonal cross section. Each fuel element has seven axial cooling holes, each 0.133 inch in diameter, providing twenty percent void fraction. The elements measure 0.75 inch across the flats of the hexagon and are bundled together in the form of a right circular cylinder approximately 35 inches in diameter. The fuel, in the form of TRISO coated beads, is incorporated into the extruded graphite matrix of the fuel element. The use of non-corrosive helium, lower core exit temperature level (1700°F versus 4090°F for NERVA) and lower temperature rise between core inlet and core exit (900°F versus 3980°F for NERVA) significantly ease the environment for the core, contributing to longer life.

Strips of pyrolytic graphite insulation material are interposed between the filler strips and the fuel elements to minimize the radial conduction of heat from the core. The radial forces which effect the bundling of the core are transmitted through a system of graphite segments and steel leaf springs to the reflector assembly which surrounds the core.

The reflector assembly is constructed from beryllium segments which are bolted to Inconel 718 rings at the inlet and outlet ends. Each segment contains a control drum, free to rotate through an angle of 180 degrees. The control drum consists of a beryllium cylinder having a sector of beryllium removed and replaced by a number of stainless steel tubes containing boron carbide. The control drums are driven through splined quill shafts from electric actuators mounted on the pressure vessel dome. Axial cooling holes are drilled in the reflector segments and control drums.

An Inconel 718 plate is supported from the reflector assembly at the core inlet end and applies an axial preload to the core through coil springs, one for each element. The springs apply sufficient load to ensure that the core remains seated on the outlet and support plate during thermal contraction of the core and also under negative "g" conditions should these arise in operations.

Radiation shielding internal to the pressure vessel acts with the external shielding to satisfy the applicable dose rate criteria. The internal shield is composed of two parts: a tungsten shield (gamma) that surrounds the radial and top reflectors, and the separate plug shield (neutron and gamma).

The internal shield is constructed from segmental blocks which are provided with cooling holes and are supported from Inconel 718 rings. This shielding is located internal to the pressure vessel for ease of cooling, to recover the energy deposited in it and is an advantage in minimizing total shield weight.

The pressure vessel is made from two weldments which are joined by means of a bolted and seal welded flange. A coaxial flow system is employed with the hot gas leaving the reactor through the central Inconel X pipe. The pressure vessel and piping walls which must withstand the system operating pressure are thus exposed only to the cooler reactor inlet gas flowing in the outer annular space.

Structural sizing of the pressure vessel has been predicated on an operating pressure of 1600 psi and an allowable material stress of 30,000 psi, and thus is consistent with the use of SA-533 Low Alloy Steel. This material is generally used throughout the nuclear industry for coded pressure vessels. However, use of Inconel 718 for the pressure vessel in this application offers the potential of increased strength capability or a reduction in pressure vessel thickness.

The turbomachinery/heat exchanger module for the LWNP is illustrated in Figure 6. It provides an integrated package of the cycle components to permit a minimum size, and therefore a minimum weight containment vessel. The module contains high and low pressure compressors, high and low pressure turbines, recuperator, pre-cooler, intercooler, and connecting ducts and shafts. The compressors are driven by the high pressure turbine while the output power is provided by the low pressure free power turbine. For this application the power turbine has been combined with an internal planetary reduction gear assembly to provide an output shaft speed of 3600 rpm at rated power compatible with the external reduction gears. Use of a low pressure free power turbine without mechanical coupling to the gas generator components permits a wide variation in output shaft speed without affecting the gas generator speed. Also included is an output shaft seal assembly for the drive shaft penetration through the containment vessel. This seal assembly includes provisions for positive metal-to-metal sealing of the shaft to the containment vessel in the event of sinking.

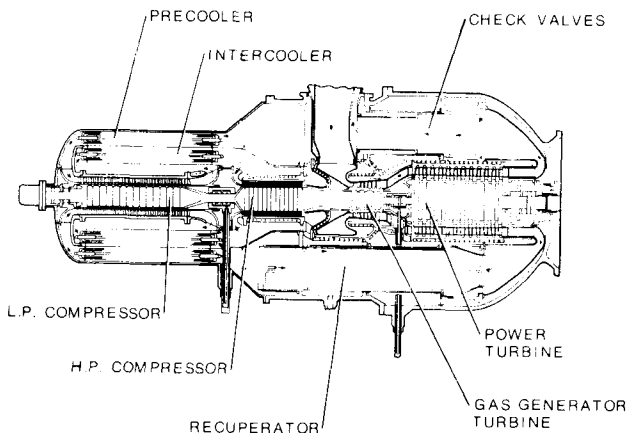

Figure 6. Turbine-Compressor-Heat Exchanger Module

The requirement for close-coupled integration of the heat exchangers and turbomachinery into one compact package results from systems requirements to minimize containment dimensions and total system weight, and also from the desire to minimize connecting piping for reliability.

As with all other portions of the powerplant system, the radiation shielding was designed considering the contributions of all components of the system. Adequate shielding is provided to limit the dose external to the LWNP to less than the required levels. The radiation sources can be thought of as two-fold; fission neutrons and electromagnetic energy (gamma) from neutron absorption and fission product decay. The total shielding function is shared by various system components and includes shielding internal to the reactor assembly, component structures themselves (including the containment vessel) and by a shield external to the containment vessel. The external shield is to be segmented to simplify removal and installation. In terms of radiation emanating from the core itself the primary shielding function is accomplished by shielding internal to the reactor assembly (plug shield and tungsten shield) and the borated zirconium hydride and borated water shields immediately around the reactor but located outside the containment vessel. Shielding for gamma radiation originating from the small quantity of fission products which could enter the helium working fluid in the worst case is provided by the component structures, including the thick-wall containment vessel.

The radial shielding is based upon the results of the extensive shield optimization of the past USAF sponsored NuERA (Nuclear Extended Range Aircraft) study (Reference 6). The reactor shield shown in Figure 2 is composed of two parts: the basic radial shield that encompasses the sides and top of the reactor, including shielding internal to the reactor vessel (tungsten) and external to the containment vessel (borated ZrH_2 and water) and a "plug shield" of tungsten, beryllium oxide and boron carbide that is after the reactor support plate. The separate plug shield is required to accommodate the helium working fluid inlet and exhaust flow paths without introducing large continuous regions of very low material density, essentially void, through which radiation originating in reactor could "stream" out, giving rise to external regions in which the established dose rate criterion would be violated. The importance of minimizing the size of the powerplant components which must be shielded and of optimizing the shield materials and design is apparent when it is recognized that the shield and containment together make up about two-thirds of the total powerplant weight.

Shaping of the shield to fit the specific needs of the application is evident in Figure 2. The shielding on the lower side is reduced to that which is adequate to protect at the bedplate and to allow limited access below the powerplant for maintenance in that area. The shield shaping reduces powerplant weight and also minimizes the height over the reactor and shield.

The estimated weight of the powerplant is 602,000 pounds, or 24.1 lb per HP, distributed as shown in Table II for the powerplant scope as stated earlier. Clearly, even though very stringent requirements were assumed as top level criteria, the results of this study indicate the feasibility of a LWNP for marine propulsion plant applications appropriate to marine gas turbines of the LM-2500 type.

TABLE II

ESTIMATED LWNP WEIGHT SUMMARY

	<u>Wgt. (1000 lbs)</u>	<u>Lb/SHP</u>
Reactor	9	0.4
Shield	385	15.4
Turbomachinery and HEX Assembly	18	0.7
Control Gas Storage	7	0.3
Emergency Cooldown	3	0.1
Equipment Shield and Fission Product Cleanup	107	4.3
Water and Auxiliary Systems	63	2.5
Power Transmission	<u>10</u>	<u>0.4</u>
	602	24.1

A slightly larger powerplant could provide output power comparable to the FT4A gas turbines installed in the Euroliner (30,000 hp maximum continuous). A powerplant of that size is estimated to have a specific weight of 22.1 lb/hr.

In a size to match the LM-5000 class of engine and provide the normal maximum input to a single shaft (on the order of 60,000 SHP), the LWNP specific weight would be approximately 15.6 lb/HP.

The LWNP concept has been derived for applications which place a premium on powerplant compactness and light weight and which also have limited on-board maintenance capability. The LWNP concept has therefore been configured for modular removal and replacement of a unit comprising the containment vessel and its internal components. A new or refueled and refurbished unit, fully checked out in a shore facility, would then be installed so that the ship could quickly return to service.

The majority of the LWNP components which are likely to require maintenance are located external to the containment where they are accessible. By design the components inside the containment are minimized, but access to most of these components for removal can be provided if further study of required on-board maintenance would indicate the need for such.

Application to a High Performance Displacement Ship

A major current application of the LM-2500 class of marine gas turbines has been in high performance displacement ships. These designs are characterized both by stringent weight and by stringent volume constraints. Consequently a typical design of the type was selected for naval architectural studies to evaluate the feasibility of using LWNP's for propulsion machinery rather than LM-2500's.

As noted under discussion of the powerplant design, the ground rules for the LWNP design study required that it interface with the basic propulsion system at the flanged couplings of the twin input shafts of the reduction gears. Spatial relationships, power level and shaft speed of the nuclear powerplant and the remainder of the propulsion system were to match at that point. Figure 7 shows the relative sizes, configurations and weights of the fossil-fueled gas turbines and the LWNP's for one shaft's worth of power.

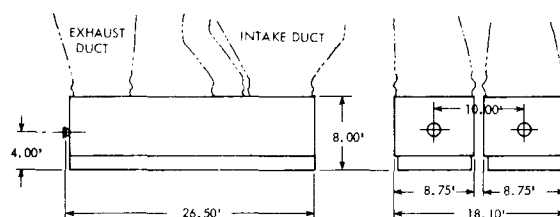

Paired LM-2500 Gas Turbines,
Weight 22.75 Tons/Unit

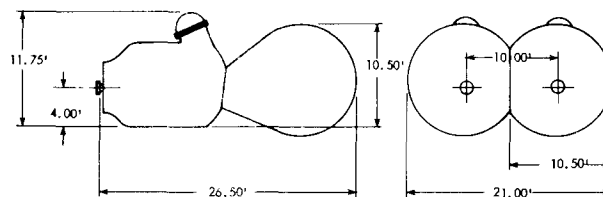

Paired 25000 HP LWNP Units
Weight 274 Tons/Unit

Figure 7. Relative Sizes, Configurations and Weights of Paired LM-2500 and LWNP 25000 HP Powerplants

To use LWNP's for main propulsion the four 25,000 HP gas turbines and their directly associated auxiliaries, combustion air supply and exhaust trunks, propulsion control equipment, foundations, and repair parts were deleted. The separate fossil-fueled ship's service generators were retained. Therefore, sufficient fuel also was retained to provide 30 days of continuous operation. This would take optimum advantage of the nuclear endurance of the propulsion plant by matching the nominal replenishment cycles for fresh and frozen provisions. Table III lists the weights of items that were removed, including a balance of 820 tons of fuel.

TABLE III
WEIGHT REMOVALS

Sub-Group	Weight (Long Tons)
201 Propulsion Units	91
204 Combustion Air Supply	56
205 Exhaust Uptakes	122
206 Propulsion Control Equipment	11
210 FO Service System	6
250 Propulsion Repair Parts	8
816 Fuel Oil	<u>820</u>
TOTAL	1114

Table IV lists the weights of items that were added by the LWNP. The weight of the reactor-turbine includes the reactor, compressor, turbines, coolers, control gas storage and helium clean-up system, emergency cooling system, containment vessel, shielding, control equipment and repair parts. Increased weight for the propulsion plant foundation was estimated on the basis of providing equal buckling strength to the basic design.

TABLE IV
WEIGHT ADDITIONS

Item	Weight (Long Tons)
Reactor - Turbines	1096
Foundations	<u>188</u>
TOTAL	1284

Figure 8 shows the equipment which was removed from the forward engine room. Similar removals occurred from the after engine room. Figure 9 shows the arrangement of the LWNP's and their principal associated equipment in the forward engine room. Only minor structural changes were required. These included strengthened propulsion machinery foundations, cut-outs in the first platform grating and relocation of a secondary stanchion, and a cut-out and doubling of the first platform hull stringer plate over twenty frame spaces. Similar minor structural changes were required in the after engine room. Retained fuel was located in forward and after tanks to compensate in some measure for concentrated weights of the reactor turbines.

Table V summarizes the effects on full load conditions with all weight removals and additions accounted for. A 170 ton increase in displacement results in 0.35 feet deeper draft. A slight decrease in GM of 0.43 feet will not significantly reduce stability characteristics. A decreased trim by the stern and slight starboard list could be corrected in further design refinements.

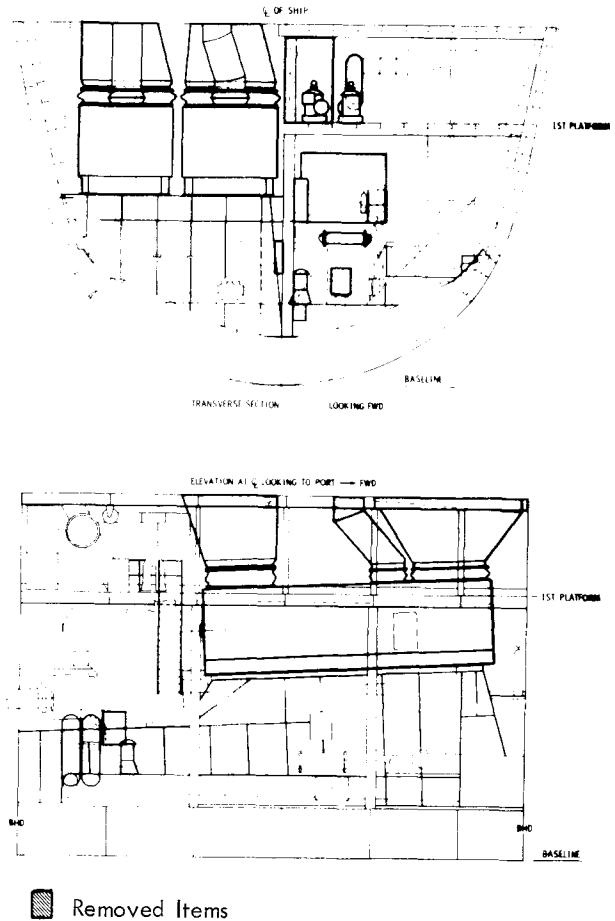
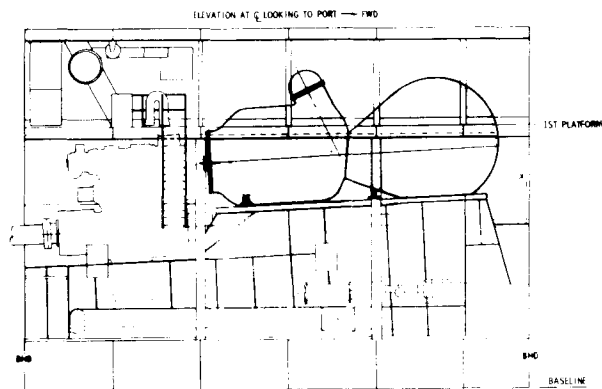
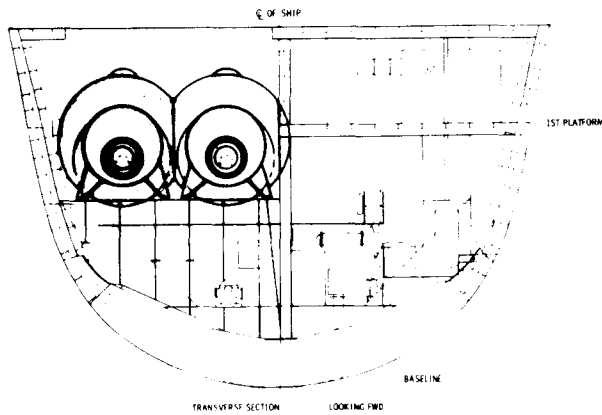

Figure 8. Forward Engine Room Machinery Removed

TABLE V
EFFECTS ON DISPLACEMENT AND STABILITY

	Base Design	LWNP Design
Displacement:		
Full Load	100 %	102.2%
Stability		
GM (Feet)	4.66	4.23

The effects of the propulsion machinery change on longitudinal strength were investigated using an adjusted weight curve to account for weight removals and additions, and a modified buoyancy curve to account for the increased draft and change in trim. The maximum hogging and sagging stresses of the modified design are shown in Table VI.



■ Installed Items

Figure 9. Forward Engine Room Machinery Added

TABLE VI

EFFECTS ON HULL GIRDER STRENGTH

	Base Design	LWNP Design
Hogging Stress:		
Max. Tension (T/in ²)	8.09	7.73
Max. Compression (T/in ²)	7.15	8.68
Sagging Stress:		
Max. Compression (T/in ²)	4.39	5.00
Max. Tension (T/in ²)	4.85	5.50

Although the highest stress is slightly greater than the highest stress in the base line design, it still is well within the 13.5 tons per square inch limit normally specified for combined stress in medium steel ship structure.

Speed loss due to the increased displacement would be about 0.17 knots.

Based on the above analysis it is concluded that the LWNP of the conceptual design discussed would offer a very feasible and attractive main propulsion powerplant for high performance displacement ships which currently are powered with multiple 25,000 to 30,000 horsepower fossil-fueled gas turbine units.

Application to a Cargo Liner

Although marine gas turbines have just begun to be employed as main propulsion units for cargo ships, a notable example of such a system, the EURO-LINER Class container ships, appeared to be an excellent basic design on which to test the applicability of the LWNP.

In past years, the space required for the machinery plant of a cargo ship was a relatively unimportant consideration due to tonnage laws in effect at that time. If the actual propelling machinery space exceeded 13 percent of the gross tonnage of the ship, then 32 percent of the gross tonnage could be deducted in computing net tonnage, which is the basis for tax assessments, harbor and canal dues, etc. As a result, a special effort was made to ensure that the space required for the propelling machinery was at least 13 percent of the gross tonnage of the ship. The tonnage laws have subsequently been modified. Therefore, that artificial condition no longer exists. Consequently in volume critical designs such as container ships it is incumbent on naval architects to retain every cubic foot of space possible for payload.

Figures 10, 11 and 12 from Reference 7, and Figure 13 show the relative space requirements of nominal 30,000 HP single screw, steam turbine, PWR nuclear, gas turbine and LWNP propulsion plants. Table VII indicates their relative tonnage requirements to the upper deck, or the maximum height required if less.

TABLE VII

RELATIVE VOLUMES/TONNAGE OF MACHINERY SPACE

Type Plant	Tonnage*	Relative Size
Steam Turbine	1864	1.00
PWR Nuclear	2113	1.51
Gas Turbine	1840	0.99
LWNP	1104	0.59

* Tonnage (100 ft³/ton) based on estimate of volume to the upper deck, or maximum height required if less.

If the LWNP system were applied to a EURO-LINER Class container cargo liner an additional four decks of 40 foot containers or approximately 48 additional units could be located in the present up-take space as shown in Figure 14. Based on available information from Reference 8 and 9, this would represent a 9 percent increase in hold container stowage or 5.6 percent increase in total carriage. Expressed in a different way the space gained would reduce engine room volume from approximately 8 percent of gross tonnage to approximately 5 percent.

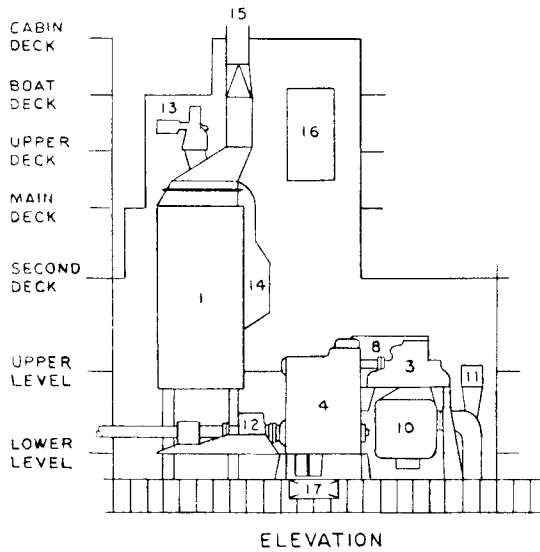
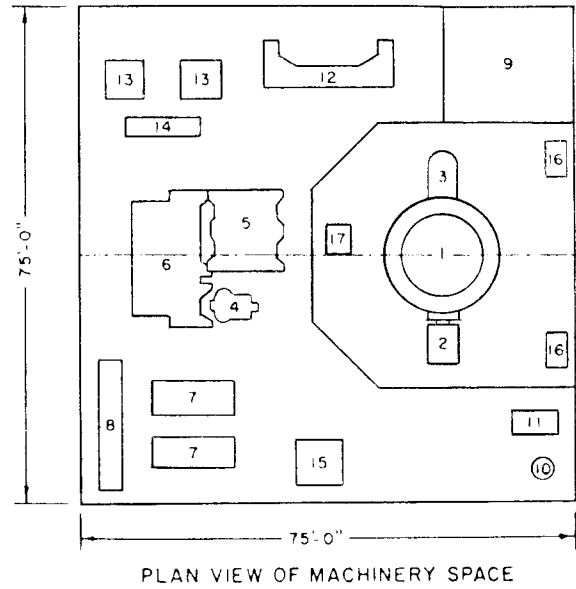
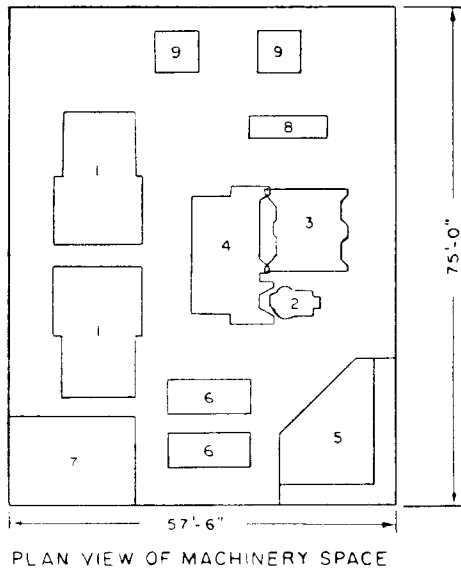

- | | |
|---------------------------------|----------------------------|
| 1. BOILER | 10. MAIN CONDENSER |
| 2. H. P. TURBINE | 11. MAIN CIRCULATING PUMP |
| 3. L. P. TURBINE | 12. THRUST BEARING |
| 4. REDUCTION GEAR | 13. FORCED DRAFT FAN |
| 5. CENTRAL CONTROL ROOM | 14. STEAM AIR HEATER |
| 6. STEAM TURBO-GENERATOR | 15. UPTAKE |
| 7. WORKSHOP | 16. DEAERATING FEED HEATER |
| 8. CONTAMINATED STEAM GENERATOR | 17. LUBE OIL SUMP TANK |
| 9. DISTILLING PLANT | |

Figure 10. Steam Turbine Powerplant

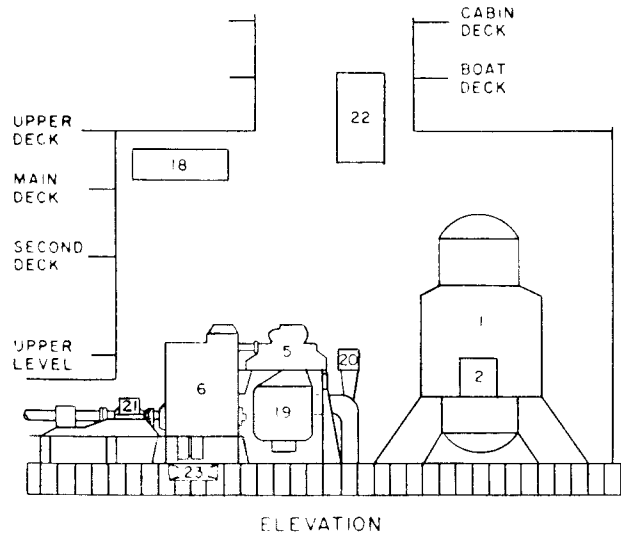

- | | |
|----------------------------|----------------------------------|
| 1. NUCLEAR STEAM GENERATOR | 12. CONTROL CONSOLE |
| 2. MAIN BLOWER TURBINE | 13. DISTILLING PLANT |
| 3. AUX. BLOWER | 14. CONTAMINATED STEAM GENERATOR |
| 4. H. P. TURBINE | 15. DEMINERALIZER |
| 5. L. P. TURBINE | 16. CAUSTIC & ACID STORAGE |
| 6. REDUCTION GEAR | 17. COMPONENT COOLING SYSTEM |
| 7. TURBO-GENERATOR | 18. LUBE OIL GRAVITY TANK |
| 8. MAIN SWITCHBOARD | 19. MAIN CONDENSER |
| 9. WORKSHOP | 20. MAIN CIRCULATING PUMP |
| 10. AIR COMPRESSOR | 21. THRUST BEARING |
| 11. AIR TANK | 22. DEAERATING FEED TANK |
| | 23. LUBE OIL SUMP TANK |

Figure 11. Nuclear Powerplant

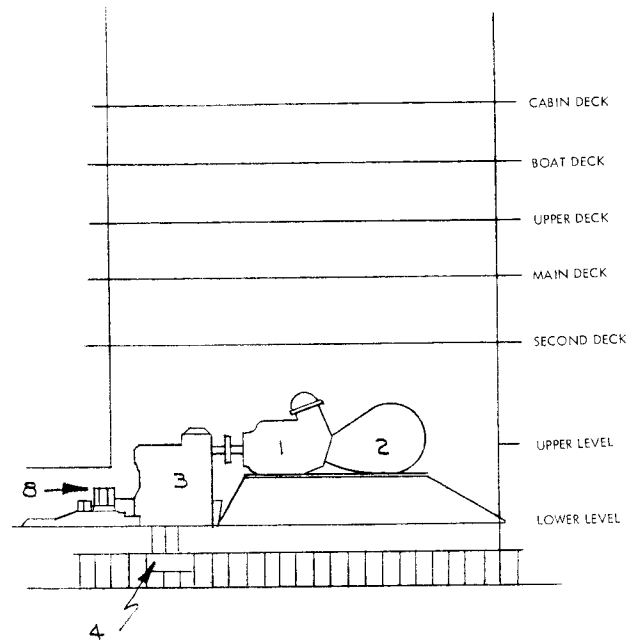
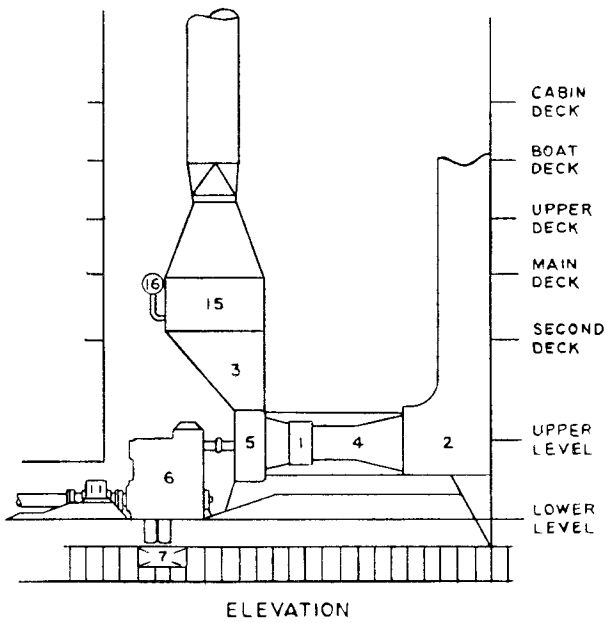
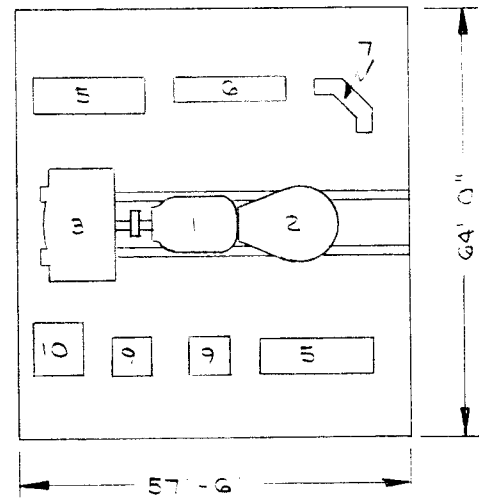
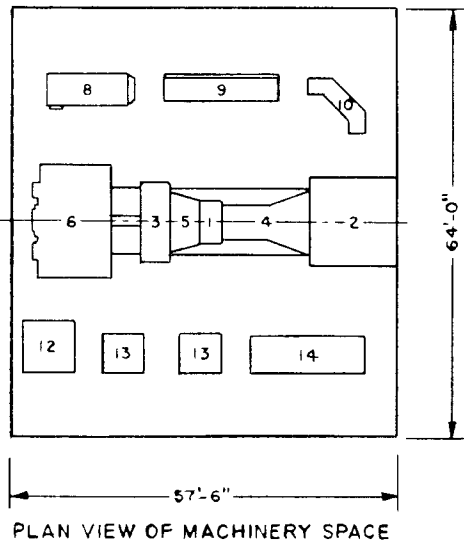

- | | |
|--------------------------|--------------------------|
| 1. MAIN ENGINE | 9. MAIN SWITCHBOARD |
| 2. AIR INTAKE PLENUM | 10. MAIN CONTROL CONSOLE |
| 3. EXHAUST DUCT | 11. THRUST BEARING |
| 4. COMPRESSOR | 12. PORT USE BOILER |
| 5. GAS TURBINE | 13. DISTILLING PLANTS |
| 6. REDUCTION GEAR | 14. DIESEL GENERATOR |
| 7. LUBE OIL SUMP TANK | 15. WASTE HEAT BOILER |
| 8. STEAM TURBO-GENERATOR | 16. STEAM DRUM |

- | | |
|---------------------------------|-------------------------|
| 1. MAIN ENGINE | 6. MAIN SWITCHBOARD |
| 2. LIGHT WEIGHT NUCLEAR REACTOR | 7. MAIN CONTROL CONSOLE |
| 3. REDUCTION GEAR | 8. THRUST BEARING |
| 4. LUBE OIL SUMP TANK | 9. DISTILLING PLANTS |
| 5. DIESEL GENERATORS | 10. HOTEL LOAD BOILER |

Figure 12. Gas Turbine Powerplant

Figure 13. LWNP Powerplant

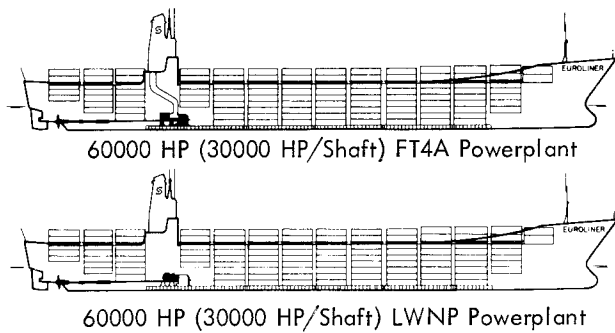

Figure 14. EUROLINER with FT4A Gas Turbine and LWNP Powerplants

Initial and operating costs are of course an important consideration. However, cost estimates are also the least certain characteristics to estimate because they necessarily involve predictions of non-scientific factors. In addition, until a powerplant has been developed and exact design features determined, cost estimates are just that - estimates. In spite of the uncertainties, consideration of the displacement ship propulsion application required an assessment of costs. Therefore, an assessment of costs was accomplished with assumptions intended to provide realistic rather than optimistic comparisons.

These LWNP cost assessments have indicated that the initial cost of a LWNP would be approximately the same as that of a marine Pressurized Water Reactor (PWR) powerplant, such as described in Reference 10, of the same output power. This result is surprising to some since the LWNP utilizes more expensive materials. However, because of its design for compactness and light weight, much less of such materials are used which also tends to minimize fabrication costs. Also similar to PWR costs are the estimated costs of the fuel for the LWNP. This result occurs because the cost of uranium is the predominant factor in the fuel costs.

The net result of the LWNP cost assessments is to indicate similar economic comparisons versus fossil fuel propulsion as have been shown many times in the past for PWR nuclear propulsion systems. What is different is that the LWNP, if developed, would require no more space than occupied by fossil fuel gas turbines. Additional cargo volume would then be available equivalent to the no longer needed air intake and exhaust discharge spaces. Design for modular replacement is also compatible with the desire to minimize dry-dock time.

From the above analysis, it is concluded that the LWNP offers a very attractive alternative to fossil-fueled marine gas turbines for special purpose high performance displacement ships where its characteristics are of significance.

References

1. R. E. Thompson, "Lightweight Nuclear Powerplant Applications of a Very High Temperature Reactor (VHTR)", 10th IECEC Paper 759164, August 1975.
2. A. R. Jones, "A Very High Temperature Reactor (VHTR) Technology", 10th IECEC Paper 759051, August 1975.
3. G. H. Farbman and R. E. Thompson, "Application of Nuclear Rocket Technology to Light Weight Nuclear Propulsion and Commercial Nuclear Process Heat Systems", AIAA Paper 75-1261, September 1975.
4. David S. Gabriel and Ira L. Helms, "Nuclear Rocket Engine Program Status - 1970", U. S. Atomic Energy Commission, AIAA Paper No. 70-711.
5. Westinghouse Astronuclear Laboratory, "Technical Summary Report of NERVA Program, Phase I NRX and XE", AEC Contract SNSO-1, TNR-230, July 1972.
6. Westinghouse Astronuclear Laboratory, "Reactor Safety Study for Nuclear Powered Aircraft, Final Report", Contract F29601-72-0035, February 1973.
7. The Society of Naval Architects and Marine Engineers, "Marine Engineering", pgs. 14 and 15.
8. ABS Surveyor, "From Europe to North America - at 28 Knots", May 1971.
9. New York Metropolitan Section SNAME, "System Integration of the GTS EUROLINER from Conception to Operation, September 16, 1971.
10. Westinghouse Electric Corporation, "Safety Analysis Study, Nuclear Propulsion System for Large High Speed Merchant Ships", MARAD Contract No. MP-4220, October 1968.